

Université libre
de Saint-Germain-en-Laye
Année 2023-2024



Arts et techniques traditionnelles dans les Amériques

9/10

**De la plume à l'objet
Oiseaux et techniques de la plumasserie**

Pascal MONGNE

Plumes américaines : premières images

"...Und ich hab aber all mein lebtag nichts gesehen, das mein hercz also erfreuet hat als diese ding.
Dann ich hab daring gesehen wunderliche künstliche ding
und hab mich verwundert der subtilen jingenia der menschen jn frembden landen..."

"... Et de toute ma vie, je n'ai rien vu qui réjouit autant mon coeur que ces choses.
Car je vis parmi elles d'étonnantes oeuvres d'art,
et je m'émerveillai devant l'habileté subtile des hommes des terres étrangères..."

(Albercht Dürer, Bruxelles, le 27 août 1520)



Christoph Weiditz (1498-1559)
Trachtenbuch, 1529
Nuremberg
Germanisches Nationalmuseum

Livre d'Heures de Maximilien I
1513-1515
Folio 41r (Psaume 21)
Décoré par A. Dürer
Munich Bayerische Staatbibliothek.

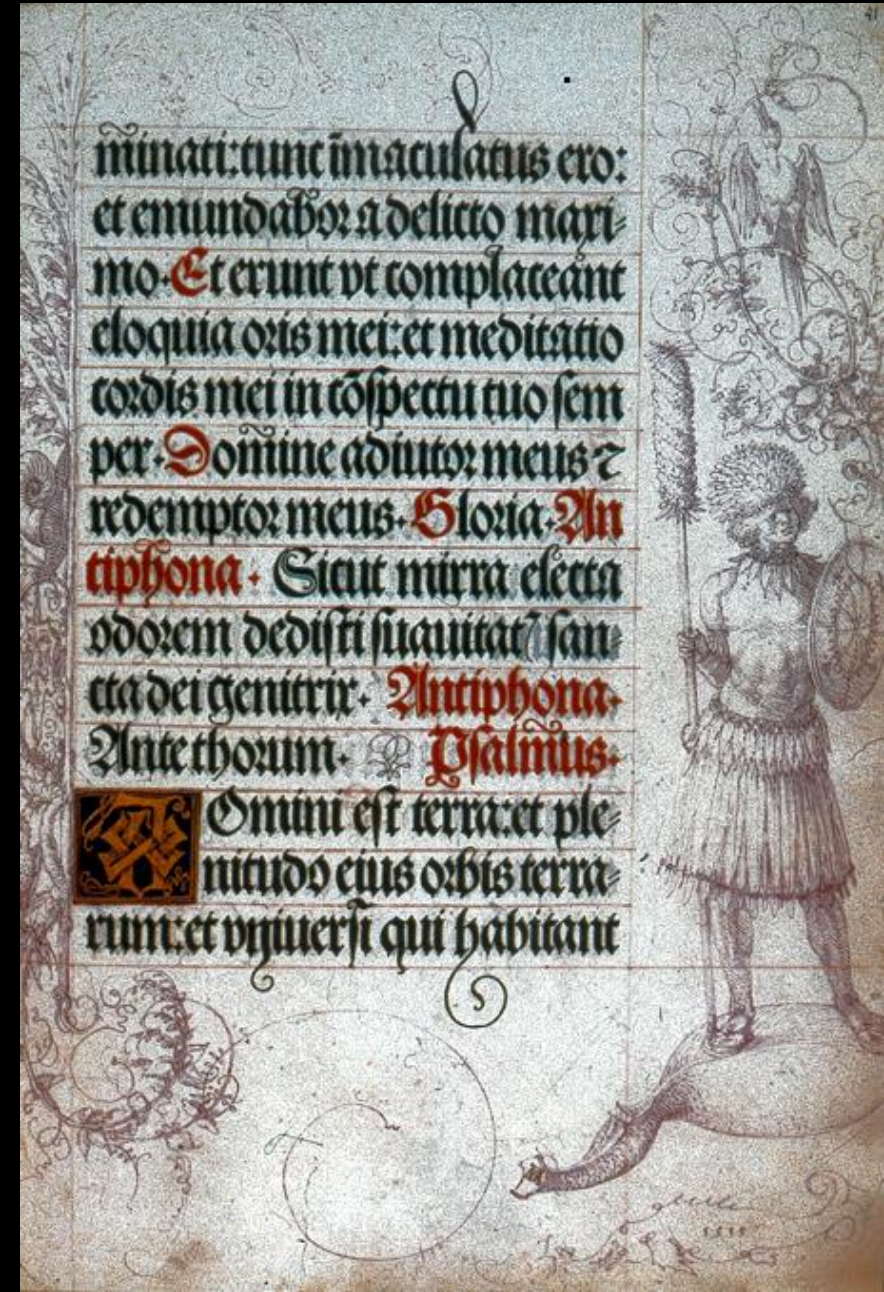

Indien imaginé : Indien emplumé

*Les peuplades découvertes
par le roi de Portugal*
Gravure sur bois, J. Froschauer ?
Augsburg ou Nuremberg, vers 1505
Munich Bayerische Staatbibliothek



Adoration des Mages, 1501-6
Vasco Fernandes (1475-1542)
Viseu Museu de Grão Vasco
Avec portrait supposé de Pedro Alvares Cabral



L'Enfer, vers 1550
Attribué à Jorge Afonso (1470-1540),
peintre à la cour de Manuel et de Jean III,
Lisbonne, Museu Nacional d'Arte Antiga.

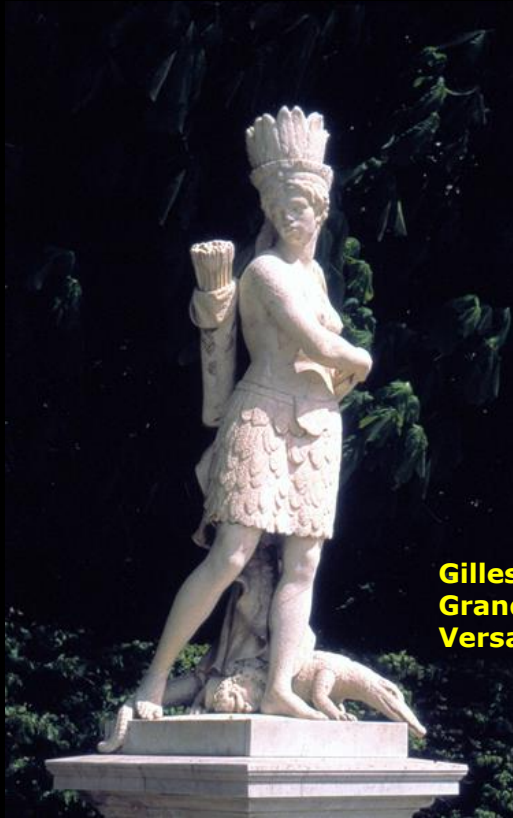

Gilles Guérin (1606-1678)
Grande commande de Colbert
Versailles, 1674



Théodore Gudin (1802-1879)
Jacques Quartier
découvre le Saint-Laurent, 1847
Château de Versailles



Giambattista Tiepolo (1696-1770)
Allégorie de l'Amérique
Grand escalier de la Residentz
Wurtzburg, 1750

Otto Dix (1891-1969)
Bilderbuch für Muggeli
(Dessin pour Martin Koch)
1922

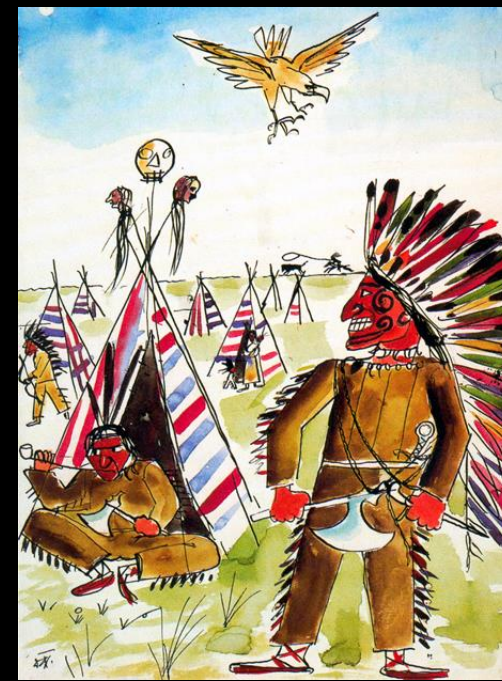

Musaeum Septalianum
de Manfredo Settala
(1600-1680)
Milan, 1666
Gravure de C. Fiori

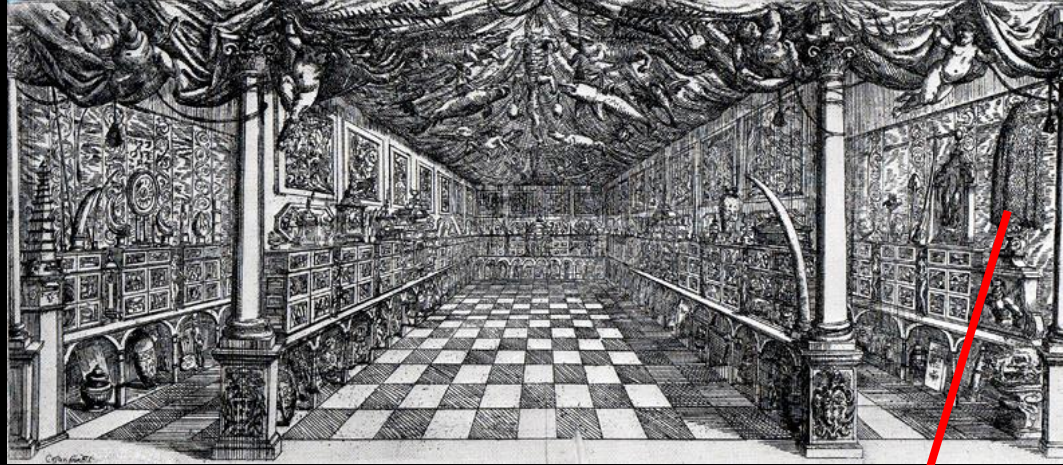

Plumes et collections



Théodore De Bry
Americas, Pars 3
(p. 174)

Manteaux
Tupinambas :



Copenhague (126 cm)



Paris (117 cm)



Bruxelles (200 cm)



Milan (155 cm)



**Toca do Caldeirão
do Rodrigues (Piauí)
vers 8000 ans av. J.-C.**

Un art ancien



Tête-trophée
Crâne, tissu, cheveux, plumes
39 cm
Nasca-Huari (800-1100)
Anc. coll. Halphen
Paris, MQB



Coiffe
Vannerie, plumes, 38
cm
Nasca (500-800)
Anc. coll. Halphen
Paris, MQB

**Jaina
Guerrier maya (Xe s. env.)
Cleveland Mus. of Art**



**« Urne funéraire »
Zapotèque, IXe-Xe s.**



**Codex Borbonicus
Déesse Tlazolteotl
Aztèque, début XVIe s.
Paris, B.N.**





Hercule Florence, 1828
Indiens Apiaká
(Mato Grosso)



Un art récent



Masque Tapirapé
(Tocantíns-Xingú)
Coton, cire, coquillage
bois, plumes
Ht. 95 cm
Madrid
Mus. Nac. de Antropología



Cérémonie Kayapo (Pará)



**Fray (ofm)
Bernadino de Sahagún
(vers 1500-1590)
Anonyme, XVIIe s.
Mexico, Museo nacional
de Chapultepec**

Aux sources d'un art

Livre XI : Animaux
- 459 entrées dont 200 sur l'avifaune
(noms d'oiseaux ou parties d'oiseaux)
Environ 125 types d'oiseaux recensés
- Seule une vingtaine utilisée en plumasserie
d'apparat

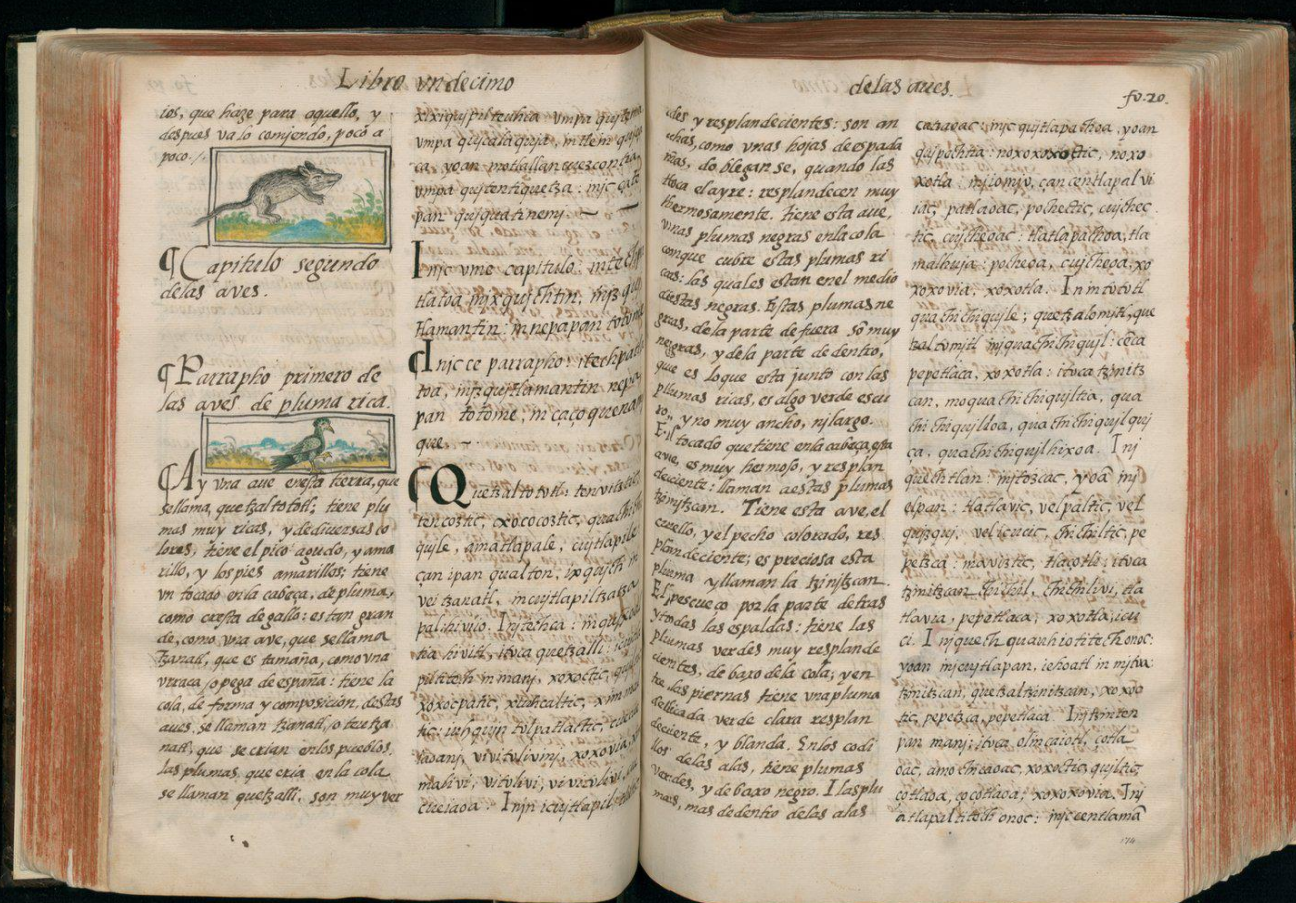

**Douze livres en trois volumes
Environ 2500 illustrations**

**Codice Florentino
(vers 1550-1580)
(Livre XI, ch.2 « De las aves »)
Fol. 19v et 20r
Florence
Biblioteca Medicea Laurenziana**

In tótotl, in ihuitl



Alo
Ara rouge
(*Ara macao*)
85 cm



Cuitlatexotli ?
Macao bleu-jaune
(*Ara ararauna*)
85 cm/110 cm



Cuitlatexotli
Ara militaire
(*Ara militaris*)
71 cm/ 110 cm



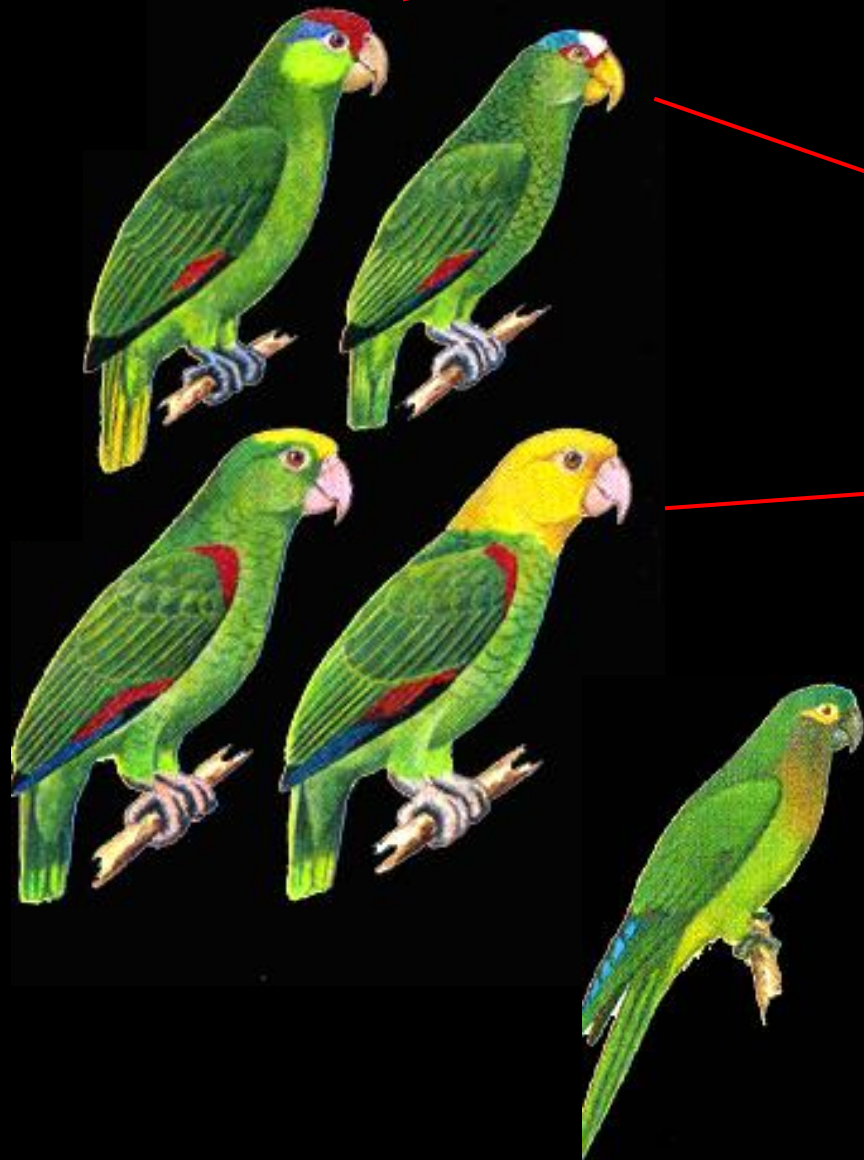

Tlacuetzali
Perroquet à couronne rouge
ou Papagayo Montes
(*Amazona viridigenalis*)



Cocho ou Cochohuatl
Perroquet à front blanc
(*Amazona alfibrons*)



Toztli
Perroquet à tête jaune
ou Cotorra cabeza amarilla
(*Amazona oratrix* ou
Amazona ochrocephala)



Quilitón
Perruche aztèque
(*Aratinga azteca*)





**Xiuhquechol
Motmot
(*Momotus lessonii*)**



**Xiuhtototl
Cotinga
(*Cotinga amabilis*)**



**Tzinitzcan
Trogon mexicain
(*Trogon mexicanus*)**



**Marc Athanase Parfait
Œillet des Murs
L'Iconographie ornithologique
Illus. : Alphonse Prévost et
Paul-Louis Oudart**

Par John Gould



TROGON MEXICANUS

Chalchiutototl
Grimpereau bleu ou Reinita
(*Cyanerpes cyaneus*)



© Antonio



Tzanal
Grive ou étourneau
(*Quiscalus mexicanus*
ou *Cassidix palustris*)
Mexique (éteint ?)



Quappachtototl
Coucou-écureuil
(*Piaya cayana*)
Amérique du sud

Zaquan
Troupial
(*Gymnostinops montezuma*)





**Aztatl ou Teoazatl
Aigrette blanche
(*Leucophoyx thula*
ou *Egretta thula*)**



**Teoquechol
Spatule rose
(*Ajaja ajaja*)**



**Xochitenacal
Toucan émeraude
(*Aulacorhynchus prasinus*)**





Huitzitzili
Colibris
(Trochilidées)

Xiuhuitzilli
Colibri turquoise
(*Calypte costae* ?)

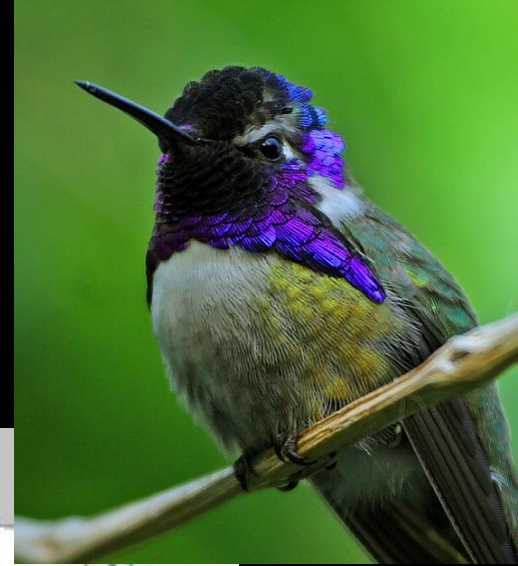

Quetzalhuilitzin
Colibri vert ou
Colibri précieux
(*Selasphorus platycercus*)



Tleutzilin ou Tleutzili
Colibri-flamme
(*Selasphorus sasin*)



Gould, vers 1830



Quetzaltotol
Quetzal ou Couroucou
(*Pharomacrus mocinno*)





Florentino
XI folio 61v

Florentino
XI folio 61r



Acquisition

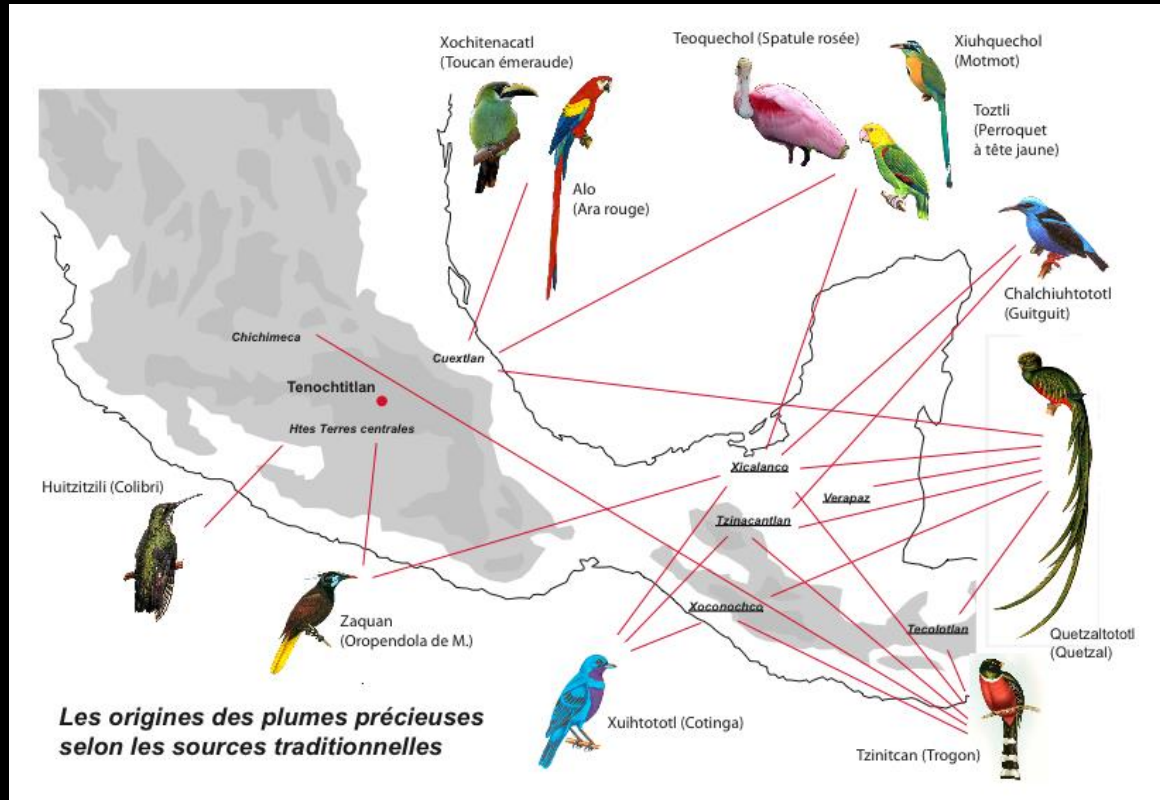

Chasseur Nukak
(Amazonie colombienne)
et sa sarbacane



Les *pochtecas* partant en mission
Codice Florentino, Livre IX-2 fol. 8r

Le chemin des plumes : *pochtecas* et marchands

Le marchand
Codice Florentino, Livre X-12, fol. 41

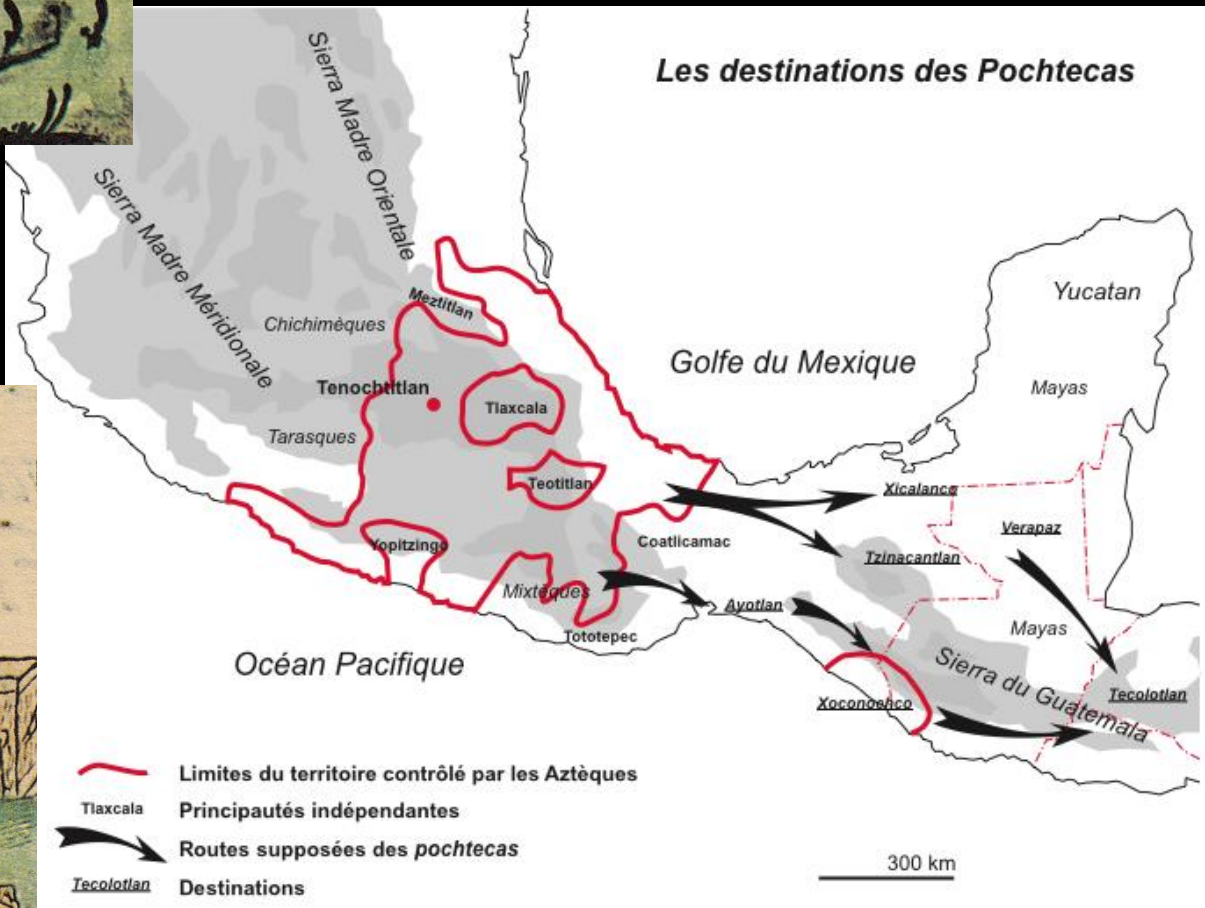
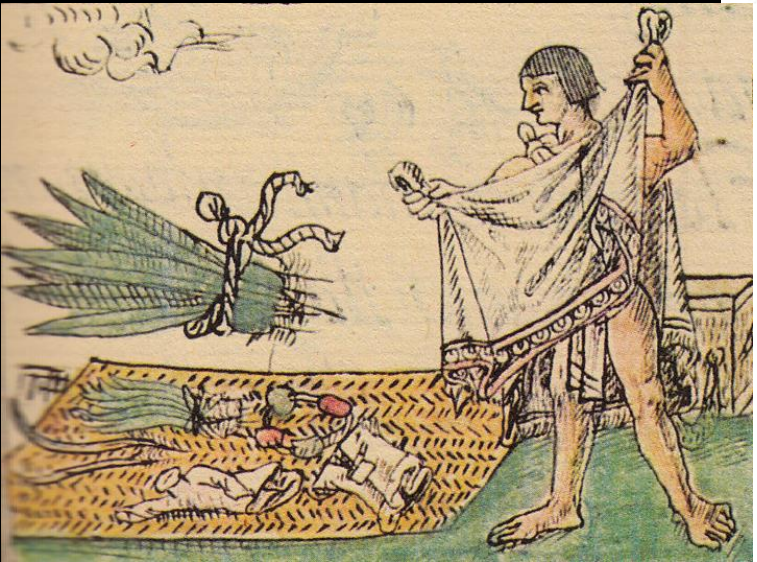

Tributs en plumes

Tochtepec
Codex Mendoza Fol. 46
Oxford, Bodleian Lib.

Un « petit » oiseau > 7/8 liasses
Un « gros » oiseau > env. 20 liasses

Une « liasse » > env. 60 plumes

En tout, plus de 30 000 liasses de plumes dont :

- Cotinga > 8800 liasses et 160 dépouilles > 1100 individus
- Perruche aztèque > 8800 liasses > 1100 individus
- Oropendola de Mont. > 800 liasses > 1000 individus
- Macao > 8800 liasses > 440 individus
- Perroquet à tête jaune > 4 liasses > un demi-oiseau ?
- Quetzal > 2480 liasses de 6/10 plumes ? > entre 9000 et 24000 ind.

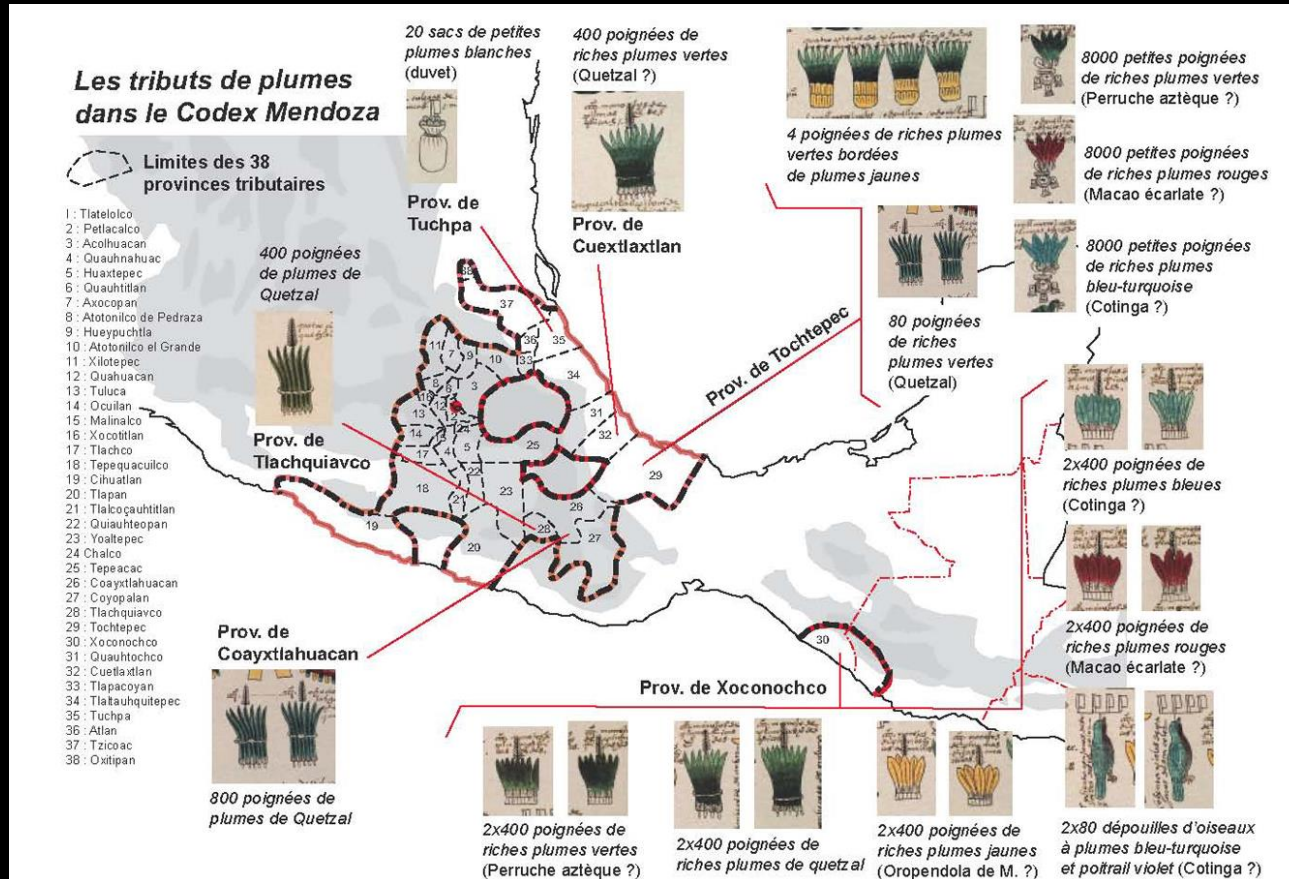
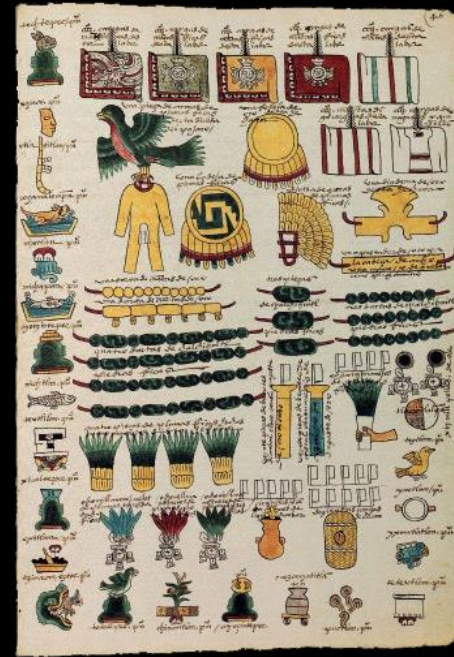

Xoconochco
Codex Mendoza Fol. 47



Florentino, XI Fol. 27v

**Le jardin « zoologique » de Moctezuma
Reconstitution d'après le Codex Florentino
A. M. Velasco Lozan
Arqueologia mexicana, X-57, 2002, p. 29**

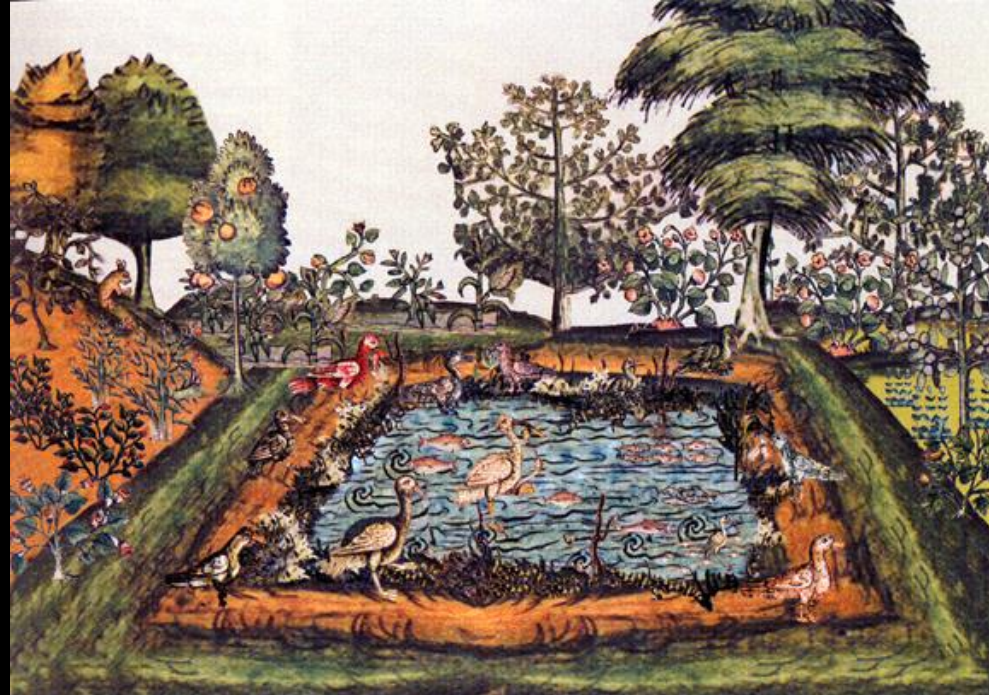

Oiseaux et élevage



**Dressage de l'aigle
Florentino, Livre XI-5 fol. 47v**

**Le Maître des animaux
Florentino, Livre VIII-14**

**Vous avez dit
 « Amantecas » ?**



Codex Florentino
 Livre IX, ch. 18, Fol. 56v-57r
 « De los oficiales de la pluma »



Plumassier et son apprenti
 Codex Mendoza



Calpixcan Amantecas

Codex Florentino
IX-20, folio 62r



Codex Florentino
IX-20, folio 63r

Calli Amantecas



Tecpan Amantecas

La plume : ornithologie

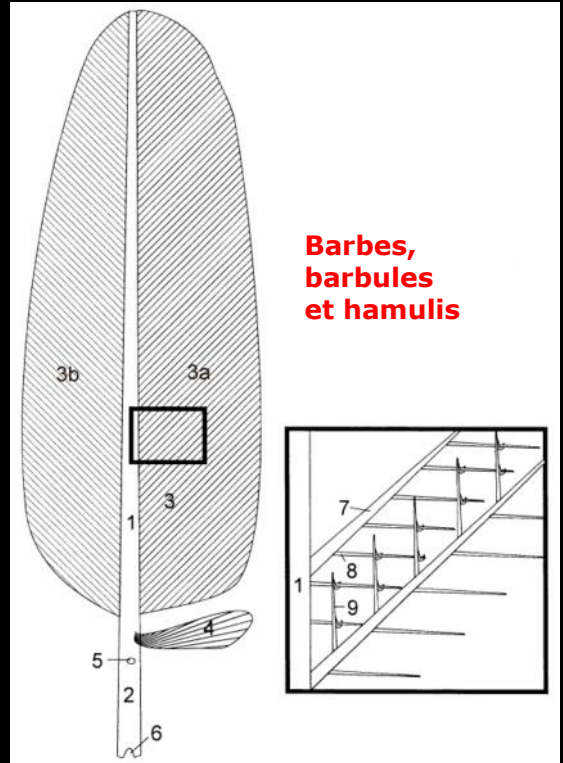
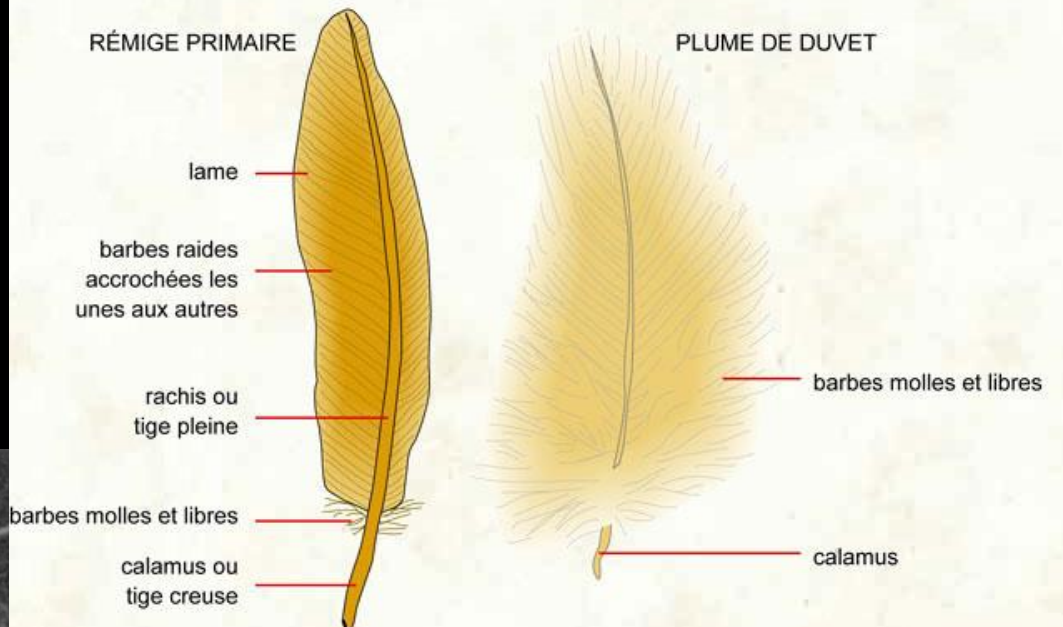
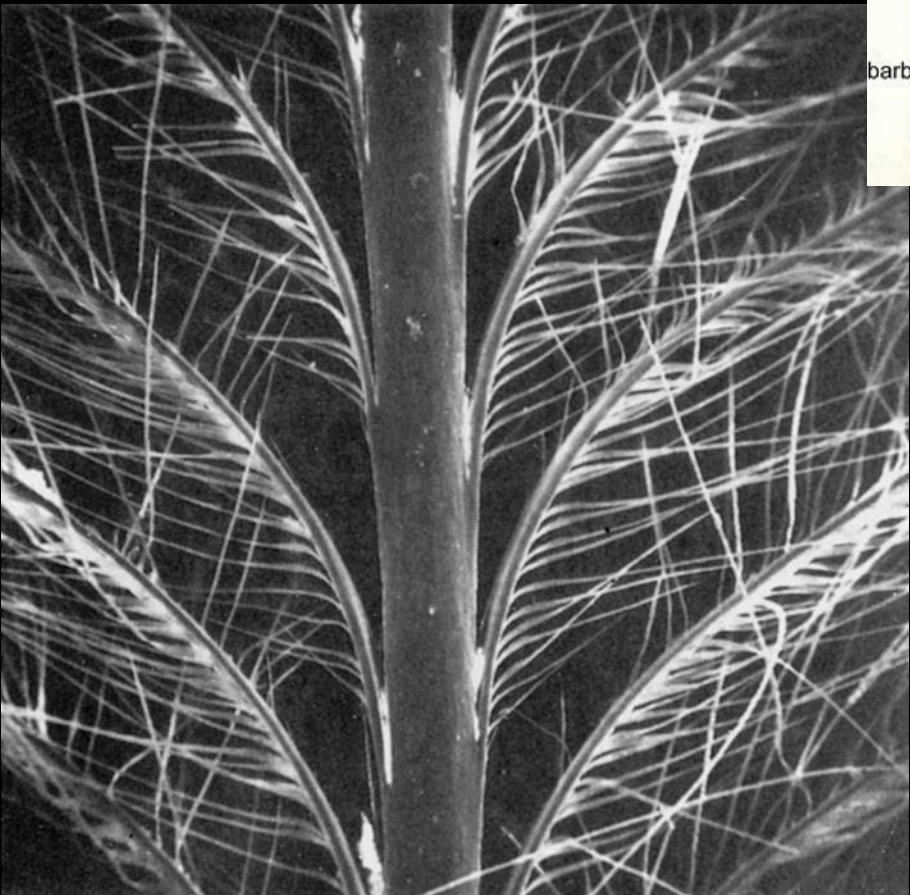

Techniques de la plumasserie

La taille



Epoutage

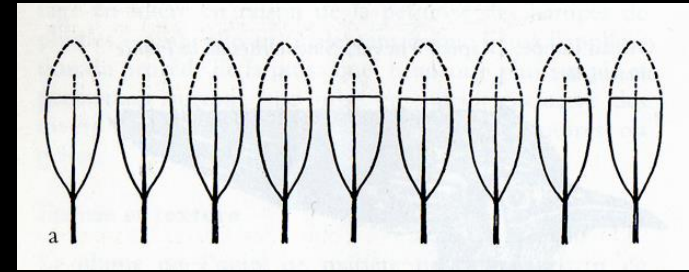

En Biseau

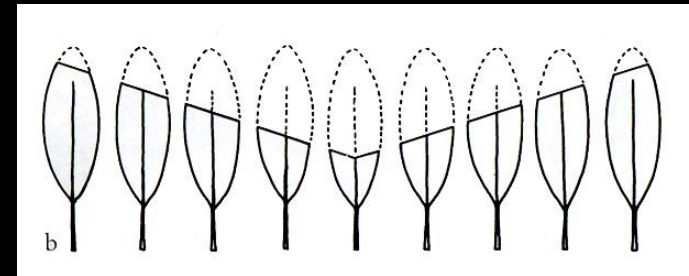

Echancrure

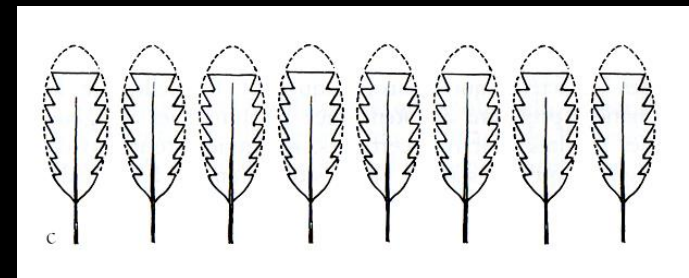

Découpage

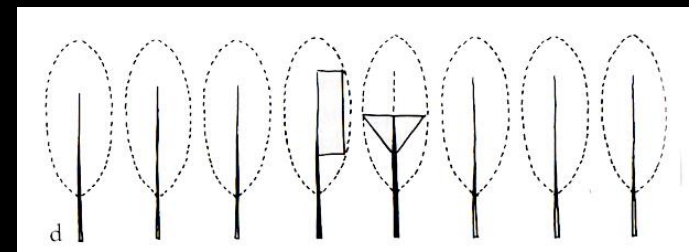

Techniques de la plumasserie

La *ligature*

En filière

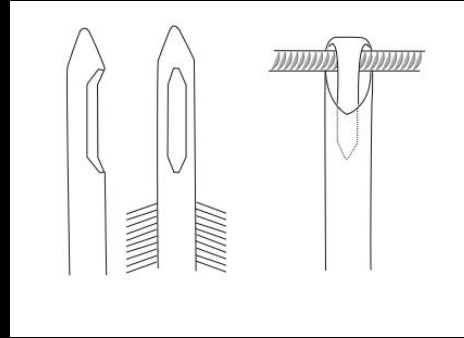

En touffe

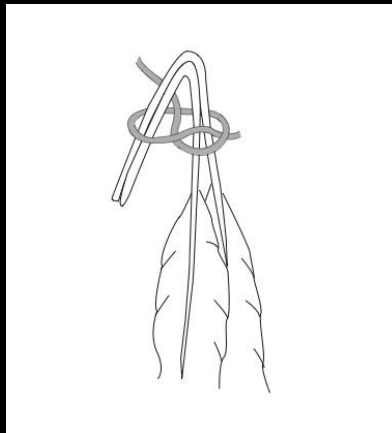

En fleur ou en pétale

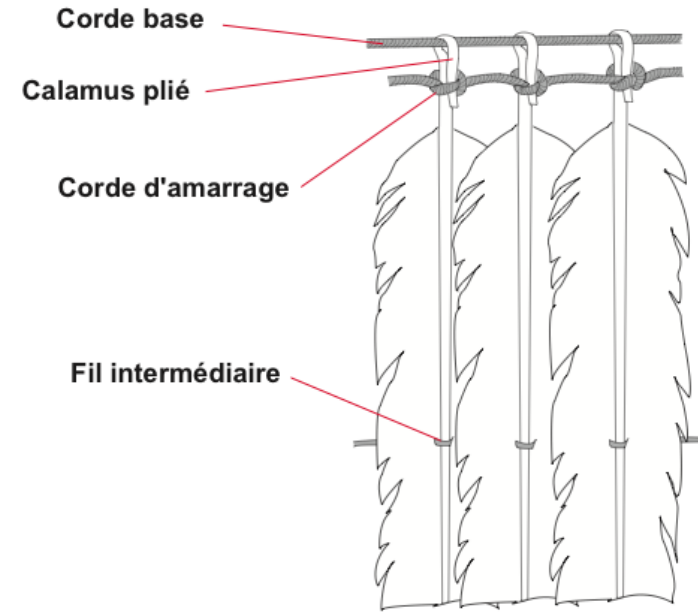
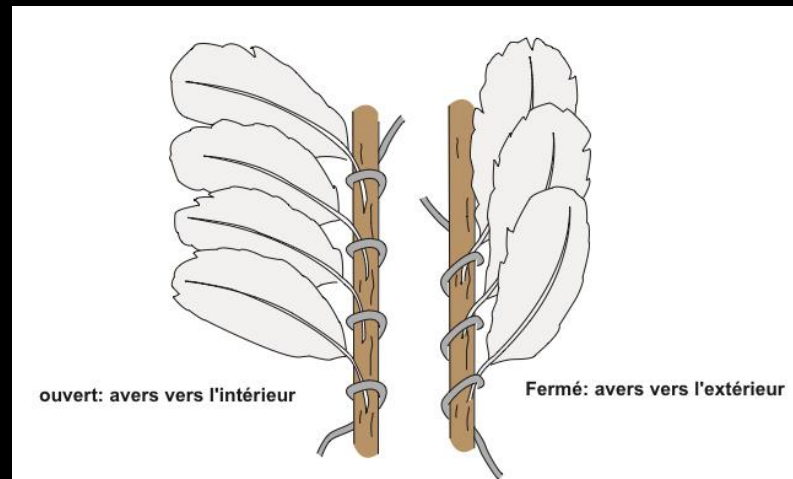

En tube

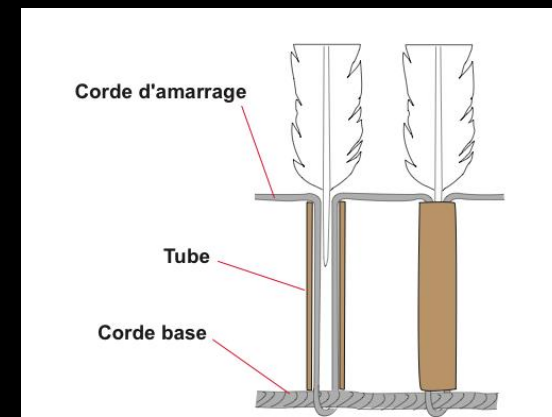

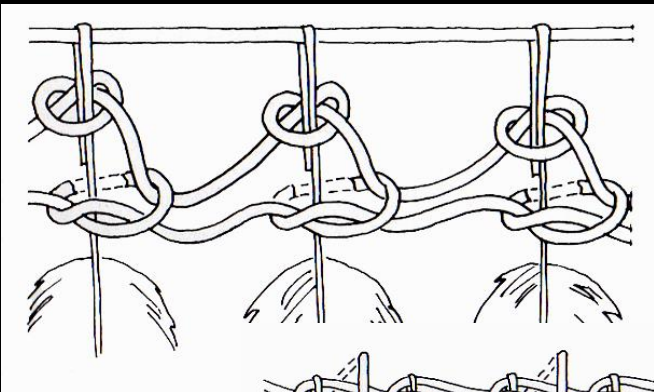

Assemblage en couture

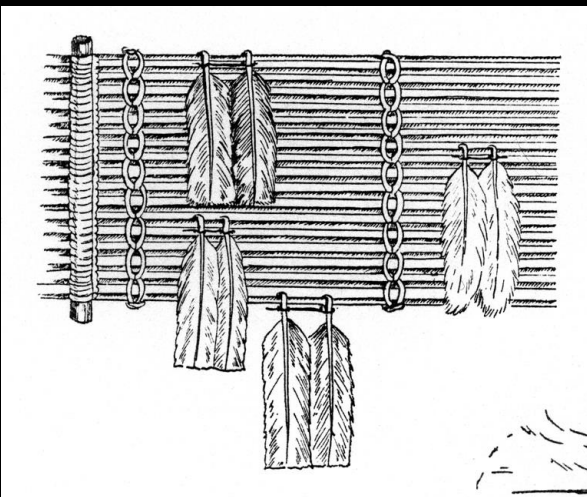
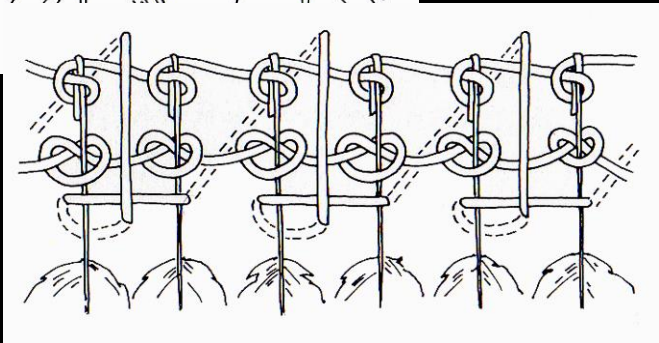

Assemblage en résille

Assemblage en trame

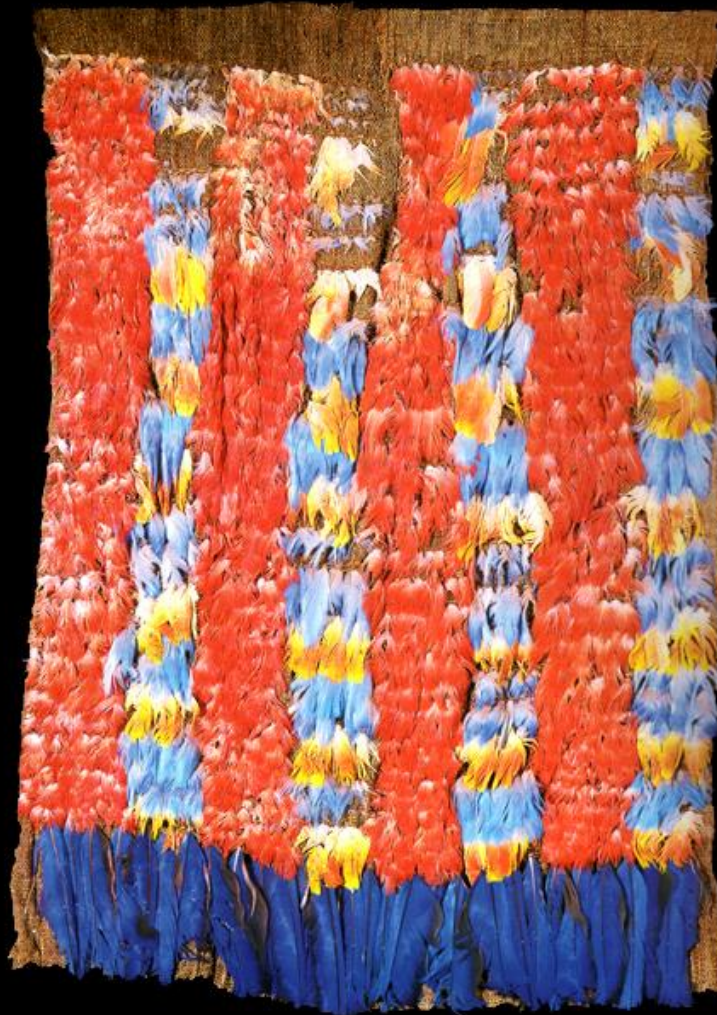
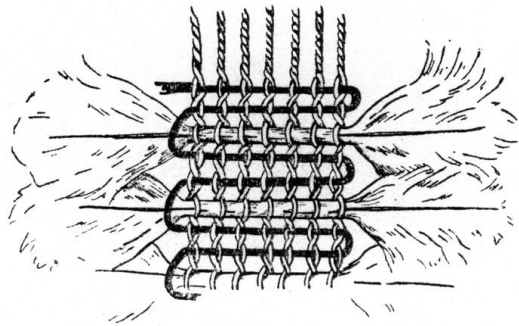

Panneau ?
Coton, plumes, 76 cm
Nasca-Huari ou Ica-Chincha
Anc. coll. Halphen
Paris, MQB

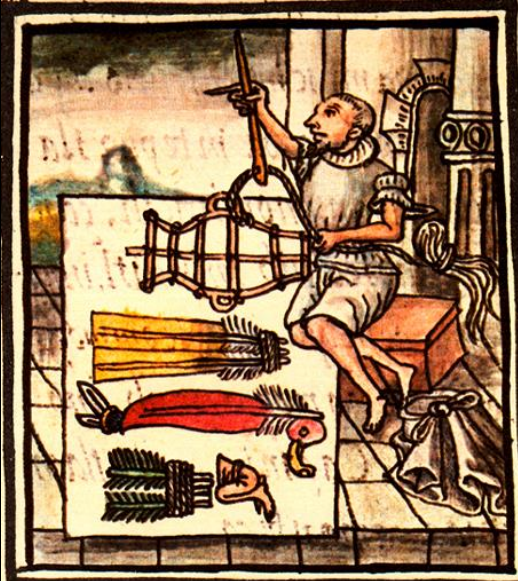

Codex Florentino
IX-21 folio 67r

Eventail aztèque, 119 cm
Collection d'Ambras
Vienne, Mus. Völkerkunde

Plumasserie aztèque et ligature



Eventail aztèque
40 cm
Templo Mayor
Mexico, MNA

Panache « de Moctezuma »
Collection d'Ambras, 116 cm
Vienne Mus. Völkerkunde



Plumasserie et tissage



Codex Florentino, IX-18, Fol. 58r
Xiuhtlati et Xilo

**Plumes cousues
sur fil de trame**

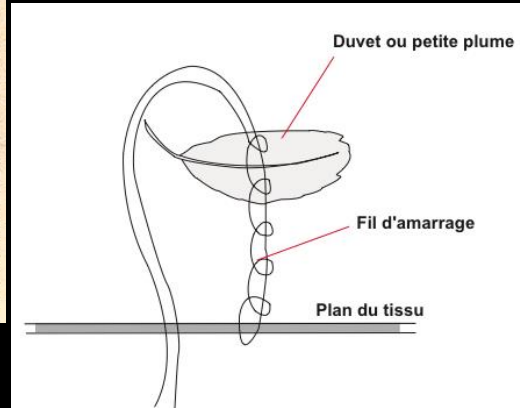

Huipil de « la Malinche »
Tlaxcala, XVIIe s.

Coton blanc et café
Broché de soie, laine et plumes
Mexico, Museo Nacional de Antropología

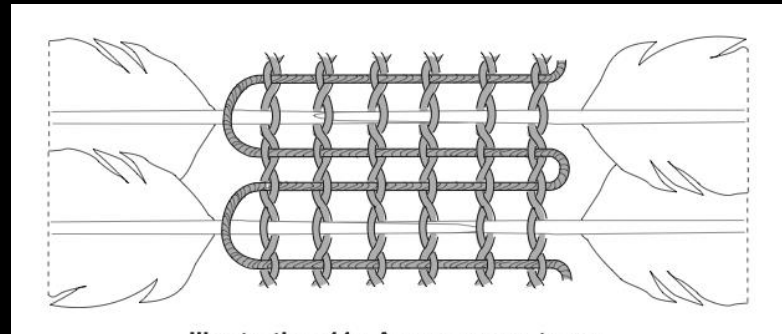

Amarrage sur trame

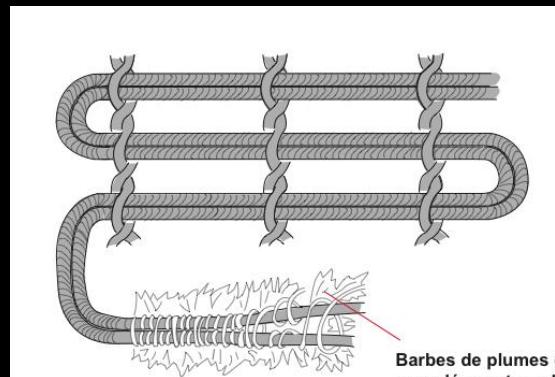

**Barbes de plumes ou duvet
enroulées autour des fils de trame**



Tissage avec fil emplumé

Les cinq étapes

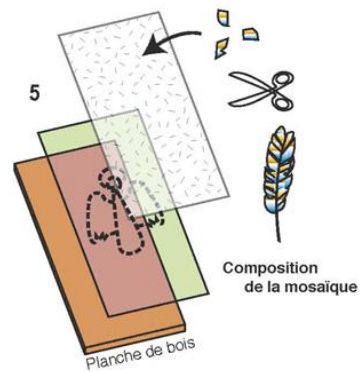
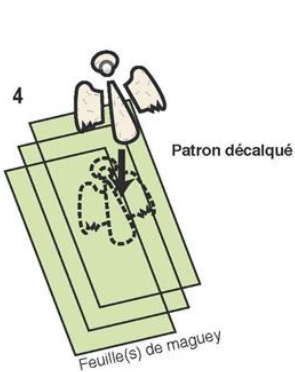
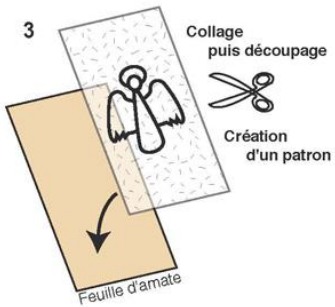
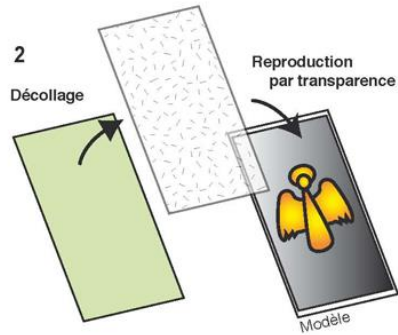
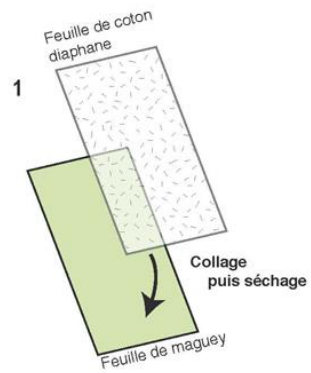

Plumasserie et mosaïque

libro nono

vasas de los mes mos officiales,
pues que los ay, en todas las
partes, desta nueva esparia
y hazen sus officios.

inic tlama tchca, inic tlatlama
chilli, inoço uel testitoc tlacui
Jolli: nimian ic mepan quioa
paoa, quitzacuoa pahoa inich
catl, quitoca iotia, ichcatlaoapa
oalli: quitemoa in qualli inisxi
petztic, inistetzcaltic, inamo
isçahoao. ioan inpedhtic, ina
mo copiltic, copiehtic: ipan qui
oa paoa inichcatl, achto conis
tzacuua, comstzacamato: nima
ic ipan con teca, concoa, compa
pachoa inichcatlapuchintli: achto
uel quiyochina, cahana, quicana
hoa, icoac inçaiuhqui tocapeiotl,
inçaiuhqui aiauitl mepan compa
choa: aub tonaiian cenmana, can
achi onishoaqui: inicoac oonish
oac, ocepça conistzacuua, ic onis
peti, ic onistetzcaui, ic onis petziui
inichcatl, inic ademo canpochin
toz, ic uel ipan onhoagui intzacutli
Aub inicoac ohoac, inoçaca sach
oac, ni man ic mocoseoa: icoac ipan
ommoçoa, oamomana inftlacuilel



Le choix des plumes
Codex Florentino
IX-21, folio 64v

Le traitement des plumes

Préparation de la colle
Codex Florentino
IX-21 folio 65v



Plumes bouillies et colorées
Codex Florentino
IX-21, folio 65r



Le découpage des plumes
Codex Florentino
IX-21, folio 65v



Tzacutli
Orchidée
(*Orchidaceae*
Bletia patula)





Rondache aztèque
Xicalcolihqui
75 cm
Stuttgart,
Württembergisches
Landesmuseum



Rondache aztèque
Azuitzotl, 70 cm
Collection d'Ambras
Vienne, Mus. Völkerkunde

Mosaïques de plumes aztèques



Delental (« tablier »)
de Malinaltenango
Berlin, Mus. Völkerkunde
125 cm (disparu)



Codex Ixtlilxochitl
Fin XVIe s.
Roi Netzahualcoyotl
Paris, B.N.



Pale ou couvre-calice
Hidalgo, vers 1540
Mexico, MNA.
28 cm

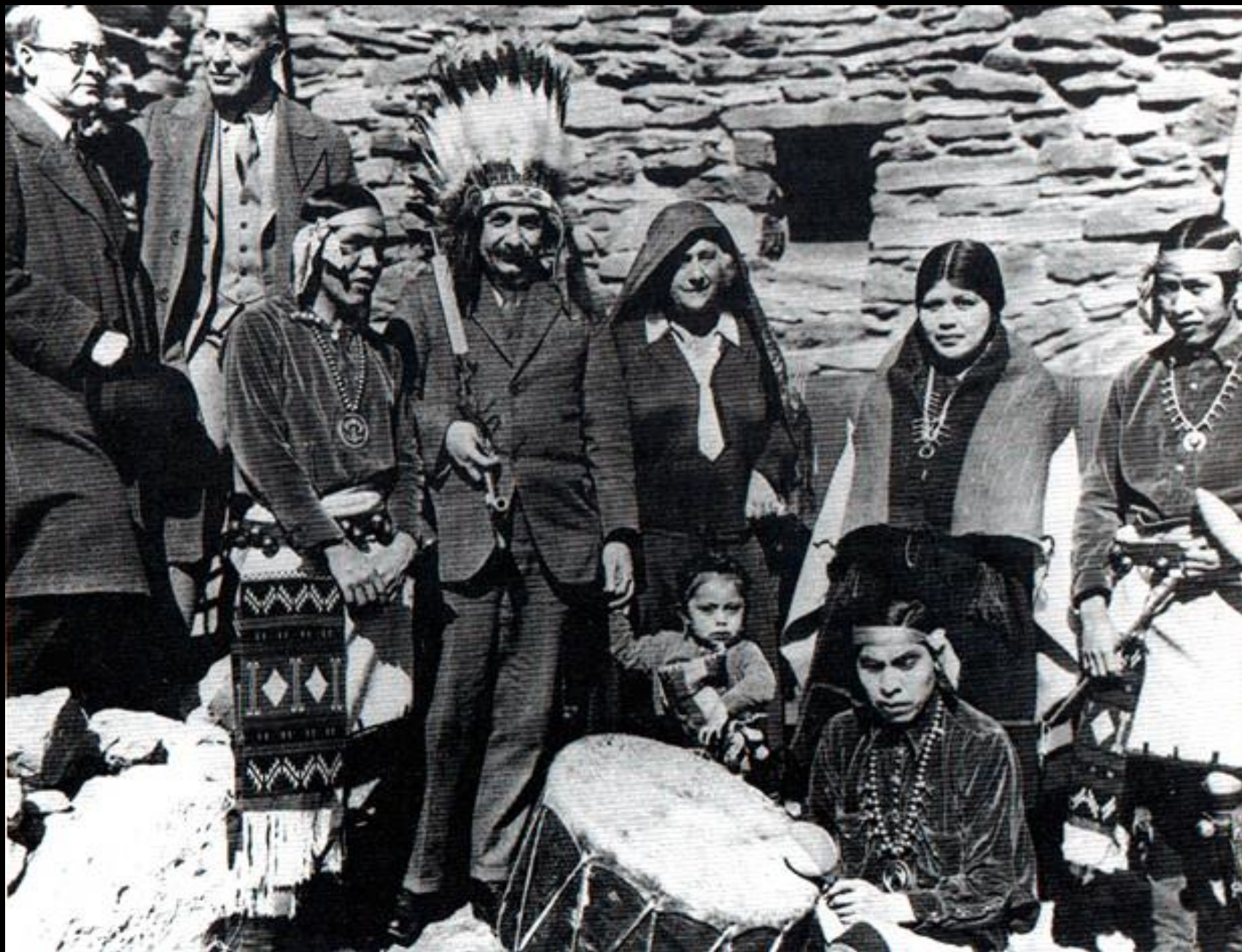

A. Einstein et Hopi, Los Alamos, 1942

